

# PRESTO PLUS

AUTOMATIC SLIDING DOOR  
CAPACITY 240 KG, INTENSIVE DUTY

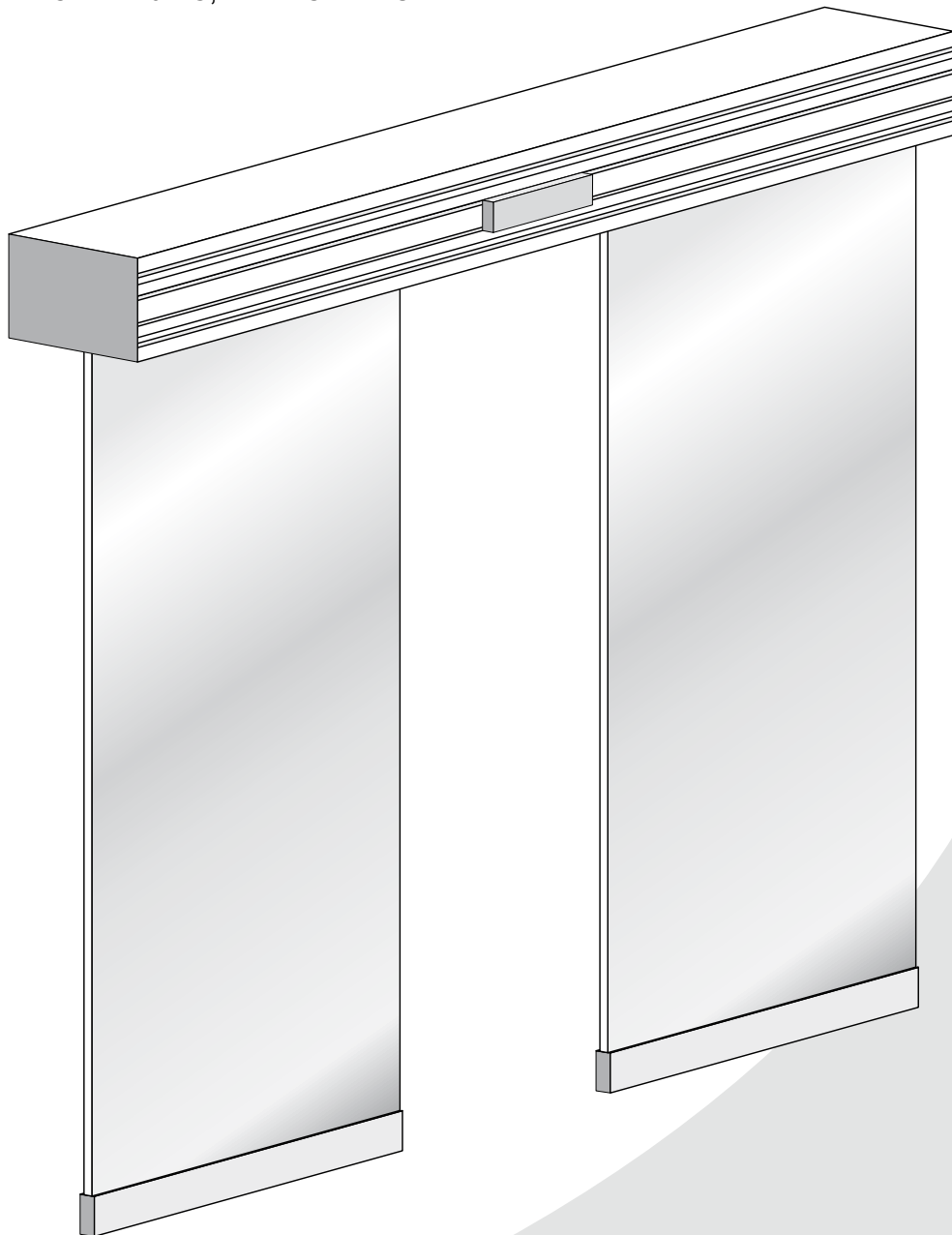

MANUAL FOR INSTALLATION AND ASSISTANCE

CE

 **DASPI**<sup>®</sup>

# Models

## Double doors

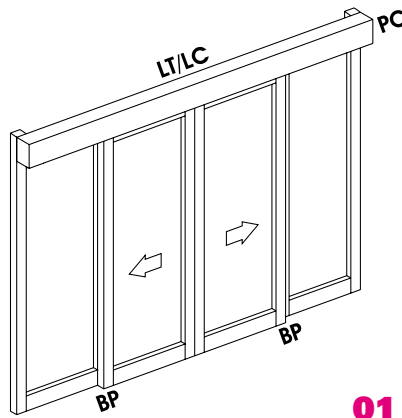
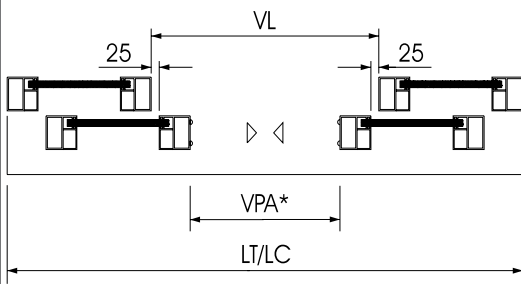

01

Two models are available:  
Automations marked 2 are for double-winged doors, which have 2 wings sliding simultaneously in opposite directions.

Automations marked 1 are for single-winged doors, which slide in one direction.

## 1 single winged door DX

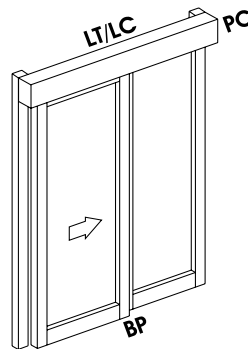
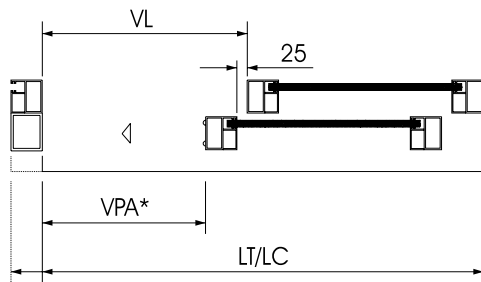

02

VPA = PASSAGE WIDTH

VL = PASSAGE WIDTH WITHOUT MOVING WING

LT/LC = CASINGS LENGTH

BP = FLOOR TRACK+SLIDING BLOCK

PC = ELECTRIC CABLE SLEEVE

Note! VPA\*  
In order to comply with safety norms measurement VPA must be less than measurement VL.

Measurement VPA is equal to VL when the column of the frame has no contusion and/or overhang which could cause a shearing effect.

## 1 single winged door SX

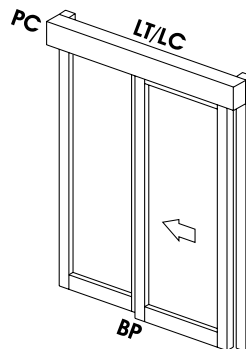
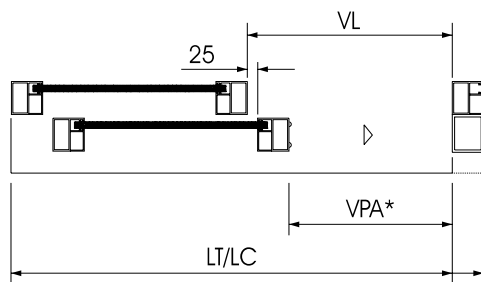

03

## INTRODUCTION

This manual contains the details and instructions necessary for the installation, assistance and maintenance of the PRESTO PLUSmax 240 kg intensive sliding doors for heavy use, with microprocessor control and encoder-positioned doors.

In order to avoid injury to persons and objects, the instructions contained in this manual should be adhered to during the various phases of installation, adjustment and technical assistance. Such operations should only be carried out by qualified technicians and third parties authorised by DASPI.

DASPI accepts no responsibility for any possible injury to persons or objects either due to incorrect installations carried out by third parties, or by not adhering to the recommended safety standards.

This manual represents no obligation on behalf of DASPI, who reserve the right to introduce changes to the document relating to technological improvements of the product without prior notification.

MAINS INPUT VOLTAGE	230 V AC +/- 10% - 50/60 Hz
DEVICE OUTPUT VOLTAGE	24 V DC - 500 mA max
POWER CONSUMPTION	150 Watt
CATEGORY	Class 2 Heavy duty use 500,000 - 1,000,000 cycles
MAXIMUM WEIGHT	1 door 240 Kg 2 doors 120+120 Kg
PASSAGE WIDTH MEASUREMENTS	1 door 800 / 3200 mm 2 doors 1000 / 3200 mm
OPENING/CLOSING SPEED	Adjustable 15/55 cm/sec
OPENING/CLOSING DECELERATION SPEED	Adjustable 1/10 cm/sec
OPENING/CLOSING DECELERATION SPACE	Adjustable 1/50 cm
AUTOMATIC RE-CLOSING TIME	Adjustable 0/60 sec
OPERATING TEMPERATURE	- 20°C / + 50°C
OPENING/CLOSING ACCELERATION	Adjustable 1/5
MOTOR THRUST	Adjustable 100/150N
PROTECTION LEVEL	IP 23

## EXAMPLES OF SINGLE-DOOR SLIDING DOORS

Recommended installation To reduce the risk of finger entrapment, the installation shown in Fig. 4 and 4a is recommended. The wall and/or support acts as a doorstop.

### Alternative installation

If an installation of the type shown in Fig. 4 or 4a is not possible, proceed as shown in Fig. 5. The speed of approach and closure must be moderate. Note! In some countries this type of assembly is prohibited by law due to the risk of finger entrapment.

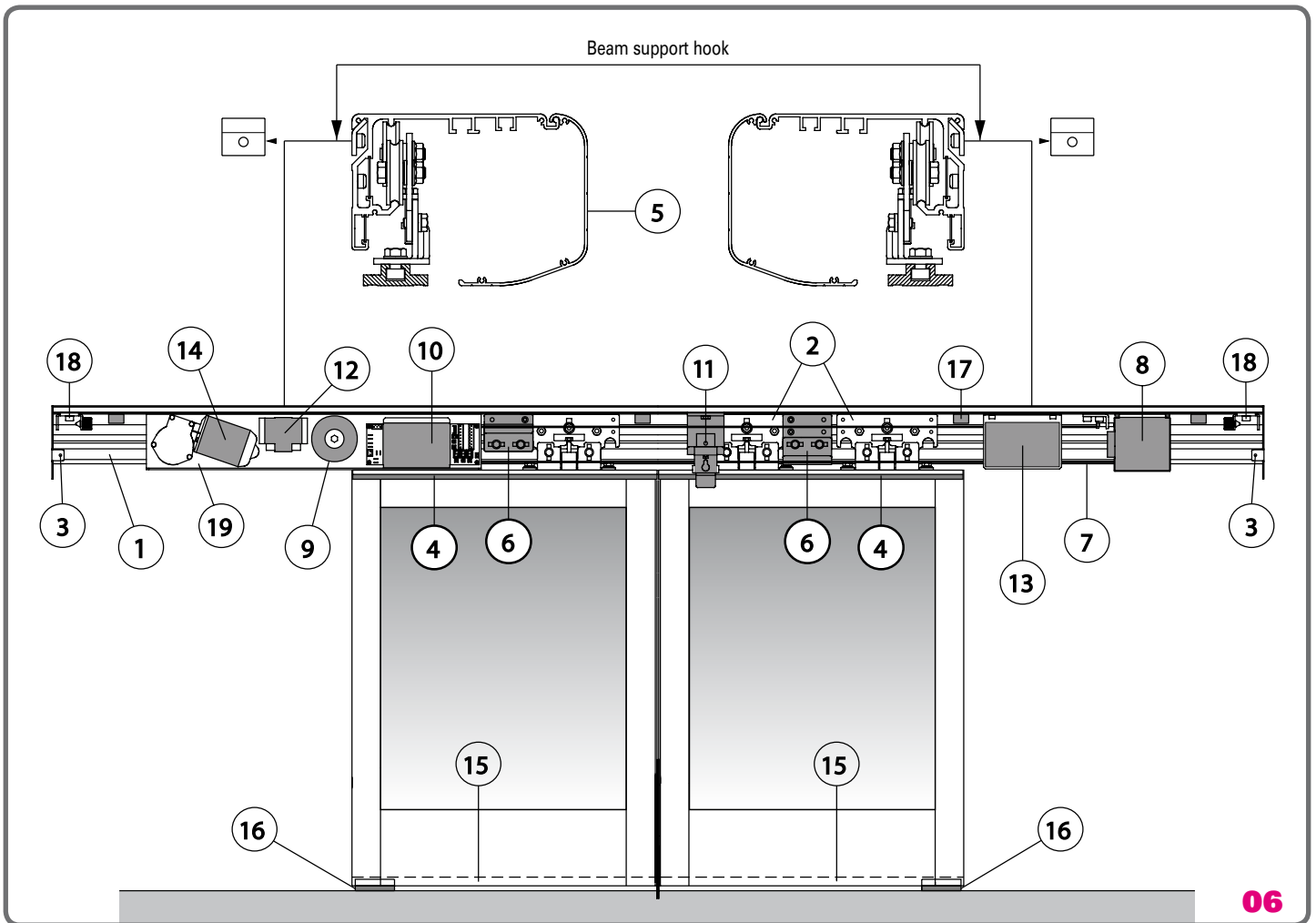
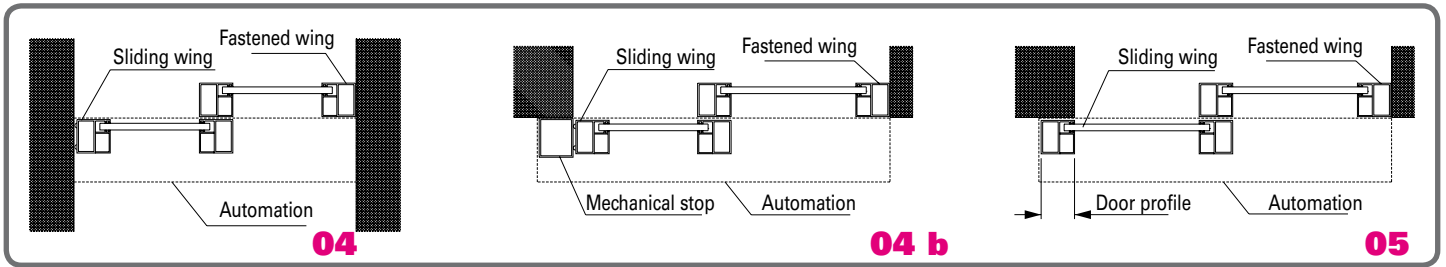

- |                            |   |                                |
|----------------------------|---|--------------------------------|
| 1 Main beam                | 8 Belt transmission with pulley and encoder | 14 Gear motor                  |
| 2 Two-wheeled carriages    | 9 Transformer                               | 15 Track for door motion       |
| 3 Mounting cover           | 10 Electronic control card                  | 16 Plastic floor sliding-block |
| 4 Door guide               | 11 Locking mechanism with manual release    | 17 Cable sleeve                |
| 5 Covering                 | 12 Back-up Battery                          | 18 Mechanical stop             |
| 6 Door coupling brackets   | 13 Photocell control unit                   | 19 Support with motor          |
| 7 Cogged belt transmission |   |                                |

## Examples of single-door sliding doors

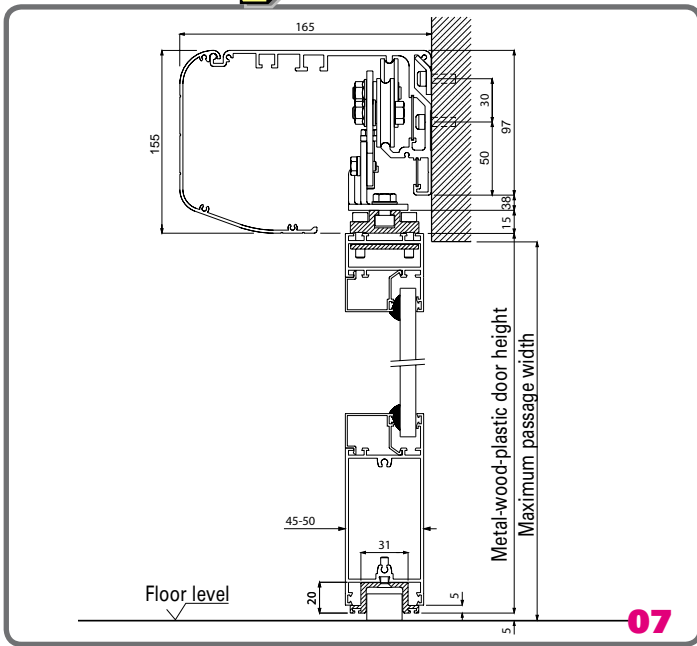

The PRESTO PLUS model has been design for installation on:

Brickwork/masonry

Metal fixtures

Wooden fixtures

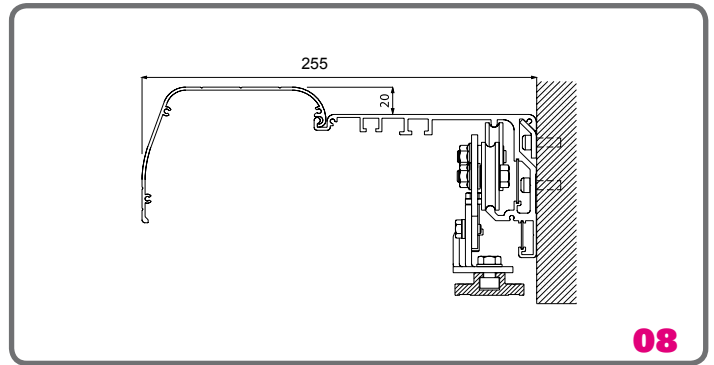

## Mechanical Assembly

### CHECK - MARK - FASTEN

To mount the beam first remove the casing.

Check that the mounting surfaces are smooth, level and aligned, and that the floor is sufficiently level and finished.

MOUNTING SURFACE MATERIAL	MINIMUM THICKNESS
Iron	2 mm (for smaller thickness use threaded rivets)
Aluminium	3 mm (for smaller thickness use threaded rivets)
Solid wall	100 mm
Solid wood	50 mm
Wall	40 mm (with smaller thickness use plugs)

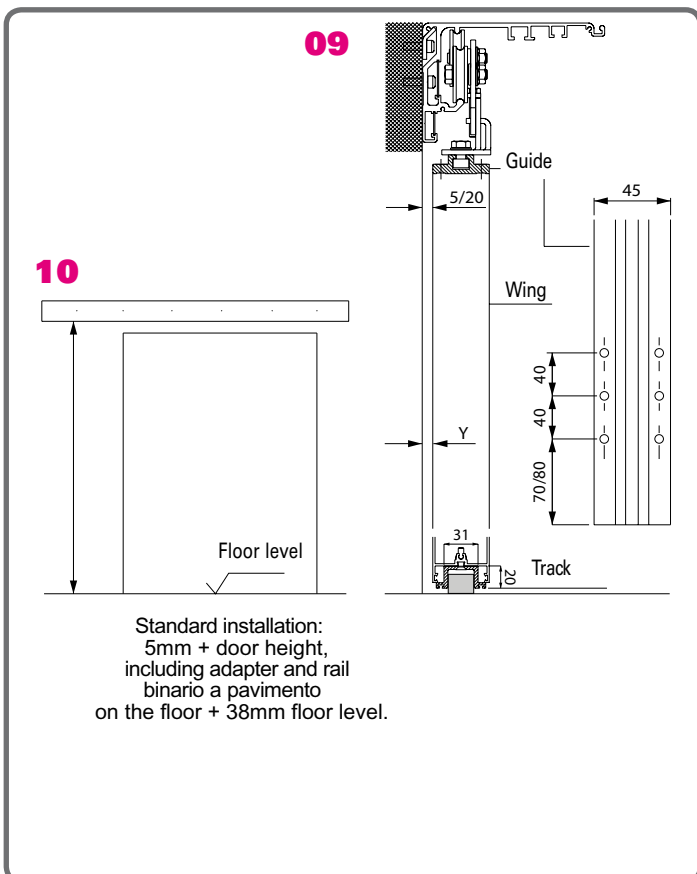

### DOUBLE-DOORS PRESTO PLUS AUTOMATION

Mark the centre of the passage width VL, aligning it with the centre of the beam. Mount the appropriate beam support hooks to the wall, as shown on page 3 and 4. Mount the beam and before fastening it, check that the two centres are lined up correctly. This ensures that the beam is correctly installed with respect to the opening.

### SINGLE-DOORS P RESTO PLUS AUTOMATION

#### OPENING TOWARDS LEFT:

beam centre = aligned with left corner of the passage.

#### OPENING TOWARDS RIGHT:

beam centre = aligned with right corner of the passage.

Mount the appropriate beam support hooks to the wall, as shown on page 3 and 4.

Mount the beam and before fastening it, check that the two centres are lined up correctly.

### STANDARD INSTALLATION OF TRACK, GUIDE & DOOR

1 Cut the guide to the size of the finished door width less than 2mm from the doorstop.

2 Ensure the upper part of the door beam is reinforced at the base. Minimum thickness 3 mm.

3 Set "Y" the perpendicular distance between the door and the vertical wall, allodoor for possible cleaning brushes.

### Mounting the beam

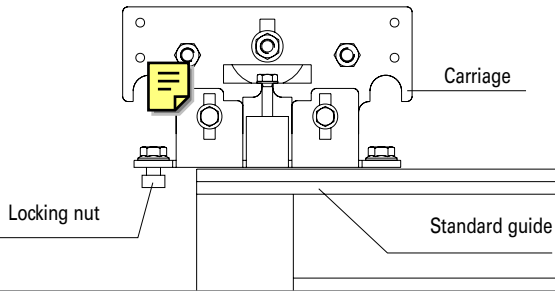

11

4 Drill the guide starting from a distance of about 80-90 mm from the end.

NOTE! The number of bored holes depends on the size and weight of the door.

5 Mark the anchorage points using the guide as a template.

6 Drill and mount the guide to the door with M6 through screws or with self-tapping cylindrical screws, diameter 5.5, depending on the material.

7 Cut the track to the size of the finished door width less than 2 mm from the doorstep.

8 Drill the track starting from a distance of about 70-80 mm from the end, fastening it under the door with countersunk, self-tapping, cylindrical screws, diameter 4.8

### Single-door, opening towards the left

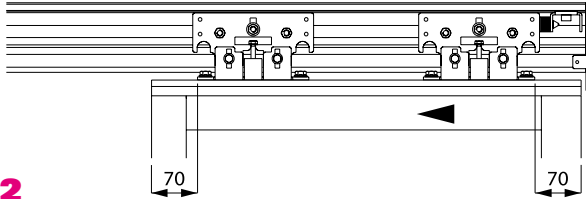

12

### Single-door, opening towards the right

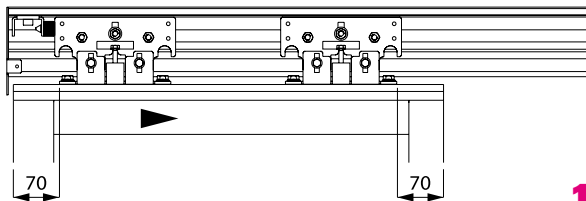

13

### Double-door opening towards left and right simultaneously

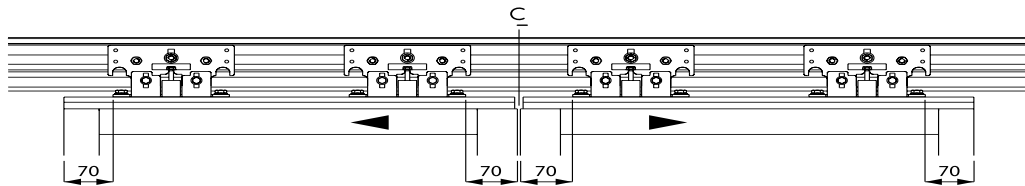

14

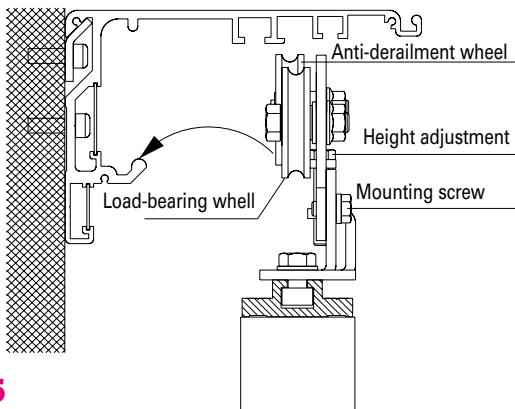

15

To assemble the floor sliding-block, it is first necessary to make a slight adjustment to the carriages and doors.

1 Ensure that the anti-derailment wheels are lowered.

2 Bring the doors near to the beam and ensure that the sliding base is clean and free from any scraps of material.

3 Hang the door on the beam, gently lifting it high, first mounting it on one side then the other, or mounting both at the same time.

4 Loosen the mounting screws and using a No. 10 open-ended spanner on the appropriate height adjustment screw of the carriage, turn it to the right or left in order to lift the door 5 mm from the floor (measurement for standard sliding block).

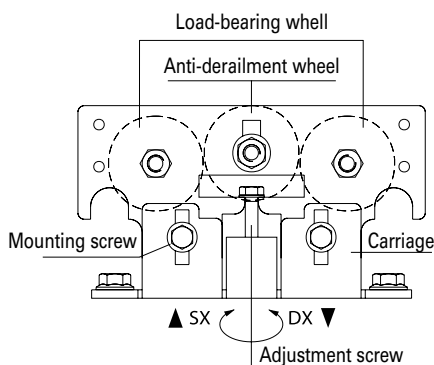

16

### NOTE!

By using the carriage height adjustment screws, the door can be lowered or raised by +/- 10 mm (with the beam mounted to the correct measurement).

### Floor sliding-block assembly

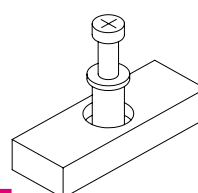

17

Rear part of the wing

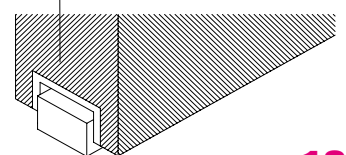

18

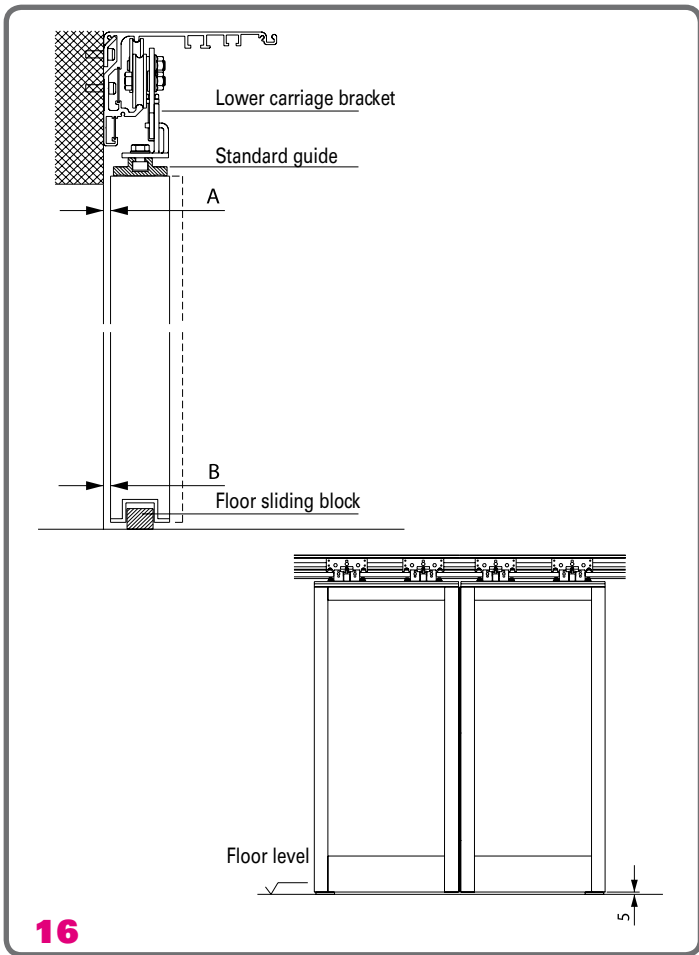

16

### FINAL DOOR ADJUSTMENTS

After mounting the floor sliding blocks, a final adjustment of the doors is necessary.

### PERPENDICULAR ADJUSTMENT

1 Distance B must be determined before mounting the floor sliding block, all-door for any possible cleaning brushes.

2 Distance A can be adjusted by loosening the two screws which fasten the lower bracket of the carriage to the guide. The brackets holes are in slot form to allow a door adjustment of about 18 mm. Before tightening the screws check that the carriages are in line with each other and with the beam.

3 Should there be a cleaning brush between the sliding door and the column or fixed wall, adjust the door so that there is a distance of about 1mm between it and the brush on all of the vertical surfaces.

### HEIGHT ADJUSTMENT

Height adjustment of the sliding doors can be carried out by means of the adjusting screws on the carriages, as shown in Fig.16 on page 5. When the final adjustment has been carried out, tighten the screws of the load-bearing wheels and raise the anti-derailment wheel.

The door must be hung sufficiently plumb and double-doored doors should be parallel to each other.

The floor sliding block should not touch the upper part of the sliding track. The presence of floor brushes should not impede sliding.

2 ante

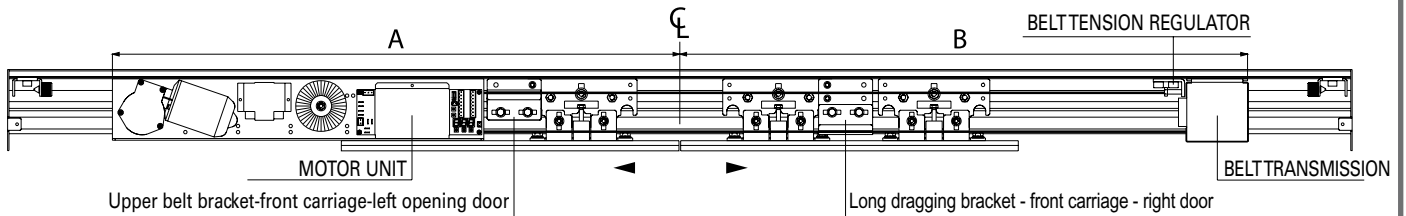

1 DOOR DX

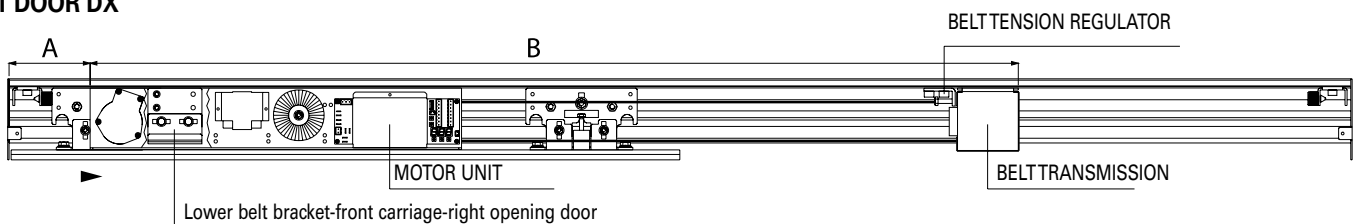

2 DOORS DX

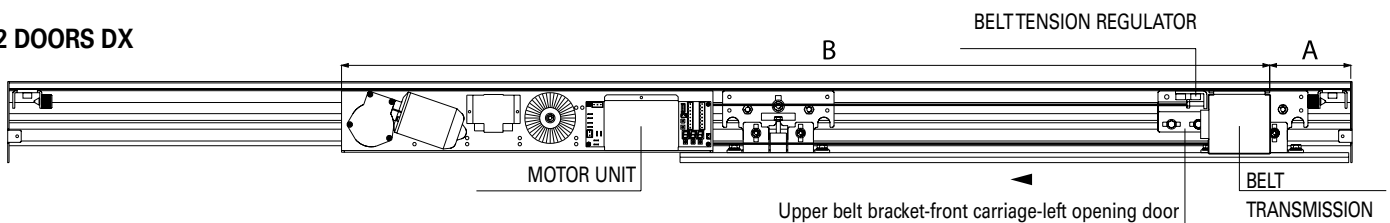

17

## 2 DOORS

VPA	A	B	BELT
1000	876	876	2x1736
1100	928	928	2x1840
1200	980	980	2x1944
1300	1032	1032	2x2048
1400	1084	1084	2x2152
1500	1136	1136	2x2256
1600	1188	1188	2x2360
1700	1240	1240	2x2464
1800	1292	1292	2x2568
1900	1344	1344	2x2672
2000	1396	1396	2x2776
2100	1448	1448	2x2880
2200	1500	1500	2x2984
2300	1552	1552	2x3088
2400	1604	1604	2x3192
2500	1656	1656	2x3296
2600	1708	1708	2x3400
2700	1760	1760	2x3504
2800	1812	1812	2x3608

## 1 DOOR DX/SX

VPA	A	B	BELT
800	120	1058	1x2104
900	120	1162	1x2312
1000	120	1266	1x2520
1100	120	1370	1x2728
1200	120	1474	1x2936
1300	120	1578	1x3144
1400	120	1682	1x3352
1500	120	1786	1x3560
1600	120	1890	1x3768
1700	120	1994	1x3976
1800	120	2098	1x4184
1900	120	2202	1x4392
2000	120	2306	1x4600
2100	120	2410	1x4808
2200	120	2514	1x5016
2300	120	2618	1x5224
2400	120	2722	1x5432
2500	120	2826	1x5640
2600	120	2930	1x5848
2700	120	3034	1x6056
2800	120	3138	1x6264

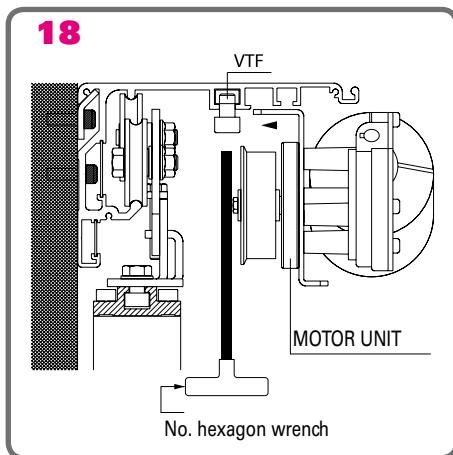

### MOTOR UNIT

- 1 Before assembling the motor unit, belt and belt transmission, it is advisable to set and pass all connection cables.
- 2 Ensure that final adjustments have been carried out on the carriages, doors and floor sliding blocks.
- 3 Mark the position points for the motor unit on the beam, as shown in the table on page 7.
- 4 Loosen or insert the two motor unit mounting screws (VTF)
- 5 Insert the motor unit with the appropriate mounting slots in the VTF screws, check the reference points on the beam and tighten the VTF screws.

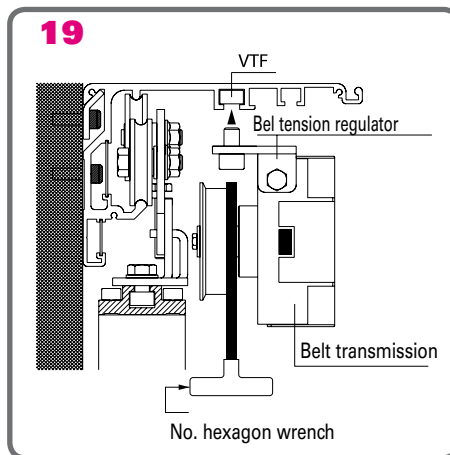

### BELT TRANSMISSION AND REGULATOR

- 6 Mark the position points for the belt transmission and tension regulator on the beam, as shown in the table on page 7.
- 7 Remove the 4 VTF screws.
- 8 Insert the belt tension regulator and the transmission using the appropriate mounting holes and the VTF screws, check the reference mark on the beam and gently tighten the VTF screws.

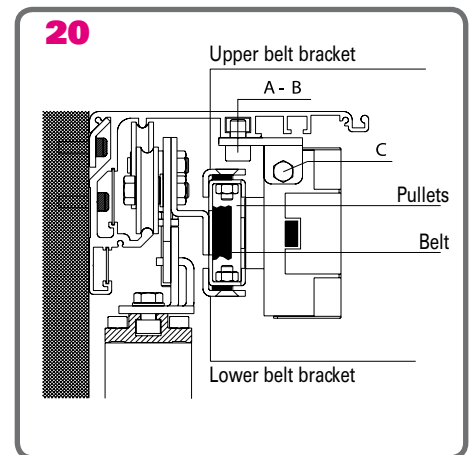

### BELT TRANSMISSION

- 9 Mount the belt transmission onto the appropriate motor and transmission pulleys, ensuring that the belt junction brackets are positioned in the direction indicated in Fig. 22. (UPPER bracket door opening towards the LEFT) LOWER bracket door opening towards the RIGHT)
- 10 Gently loosen the A screws of the tension regulator, tune it with the transmission belt and tighten the A screws.
- 11 To set the belt tension loosen the B screws of the transmission and turn the C screws until the appropriate belt tension is obtained.
- 12 Tighten the B screws, checking that the transmission is in line with the beam.

### 1 Wing DX - Opening towards the left

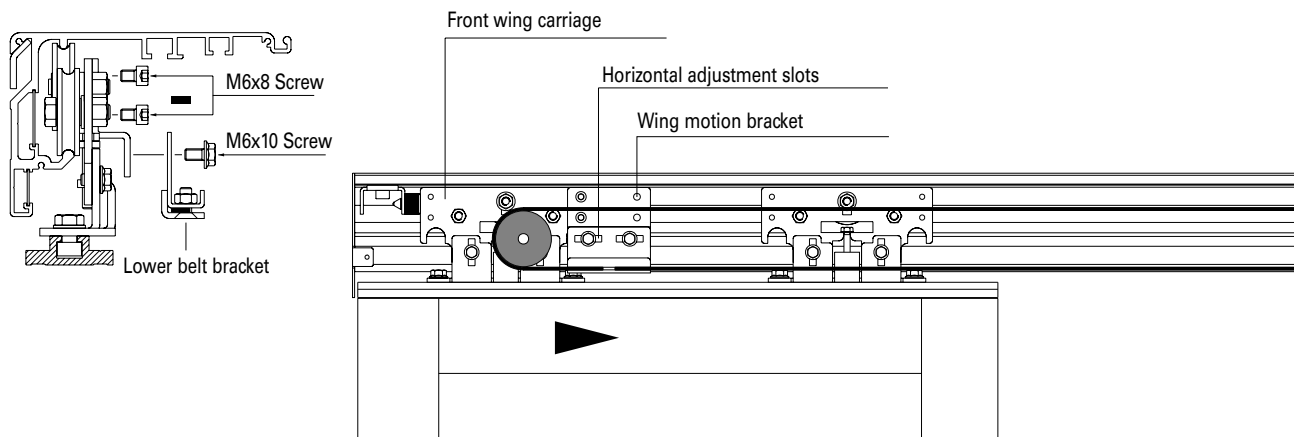

21

### 1 Wing SX - Opening towards the right

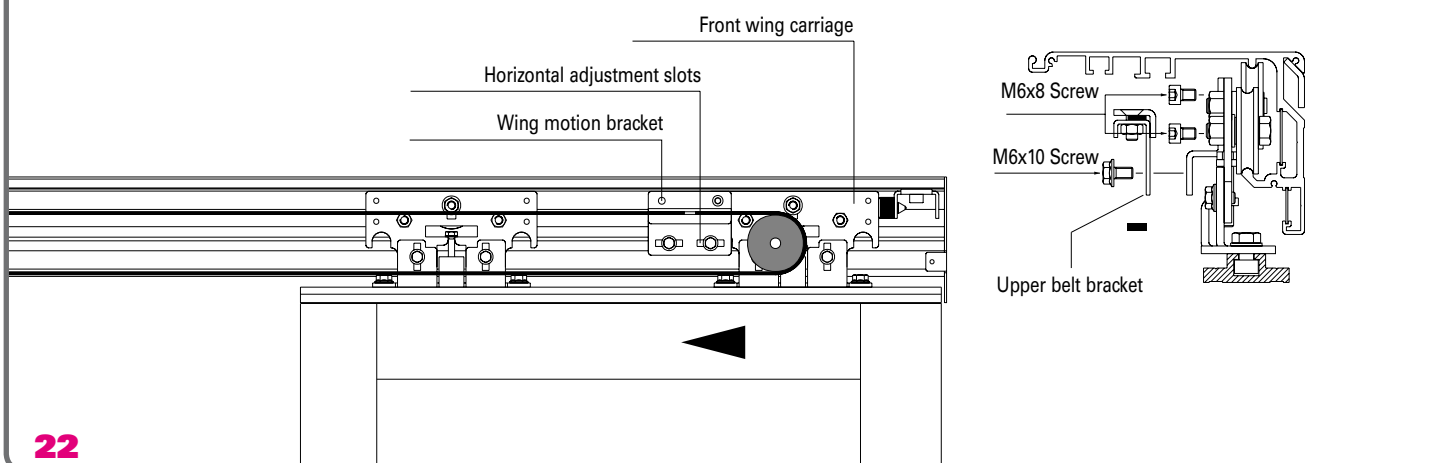

22

### 2 DOORS - simultaneous opening towards the left and right

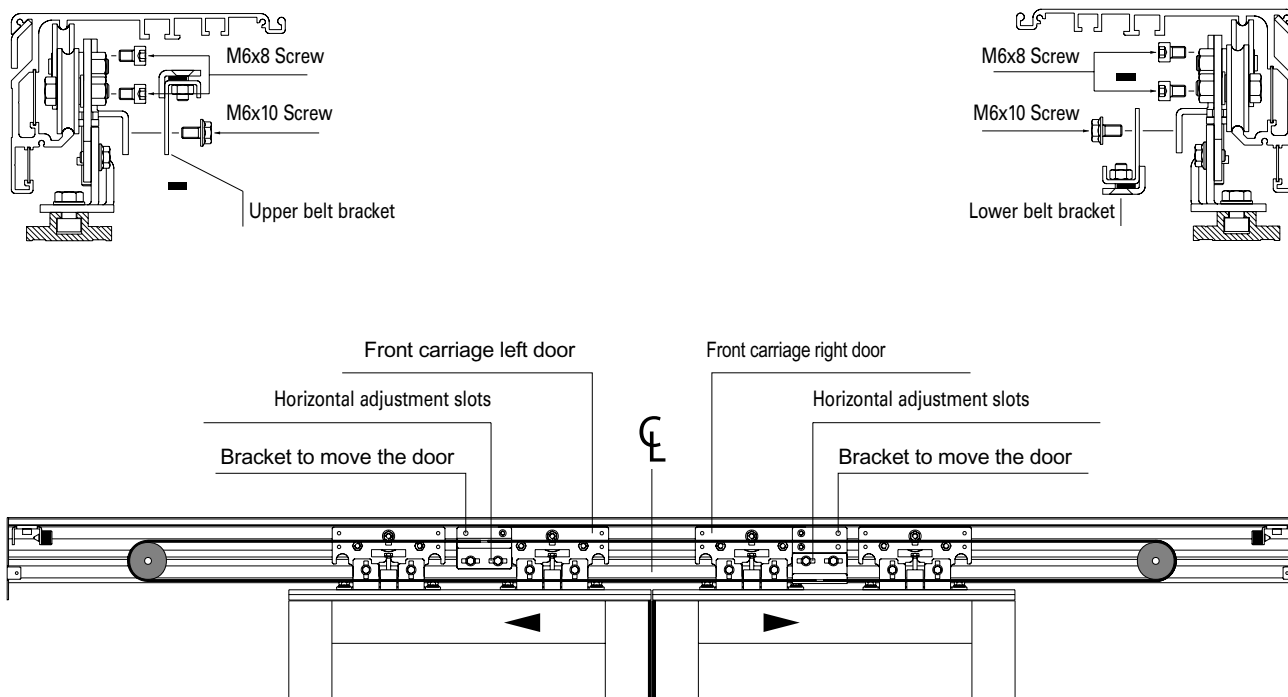

23



**2 DOORS**

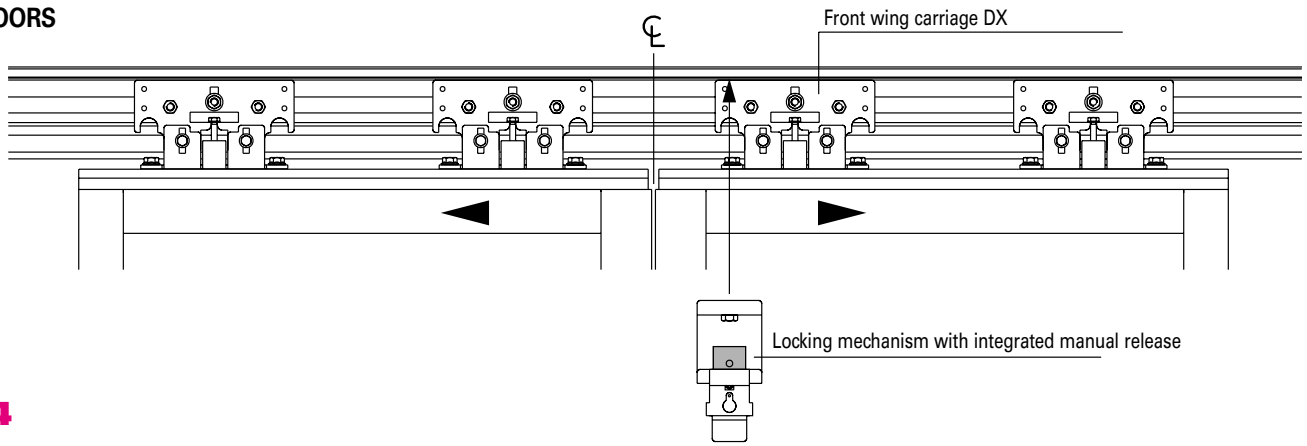

**24**

**1 ANTA DX**

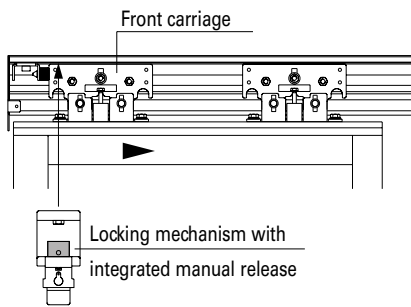

**25**

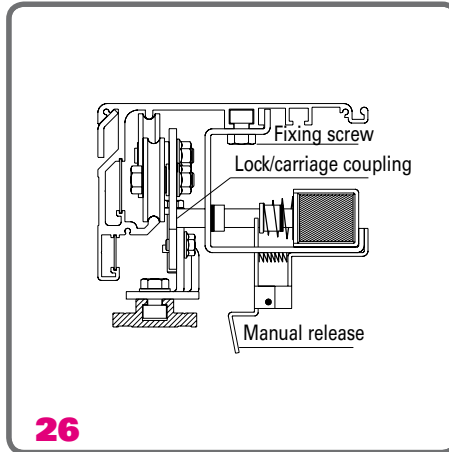

**26**

**1 ANTA SX**

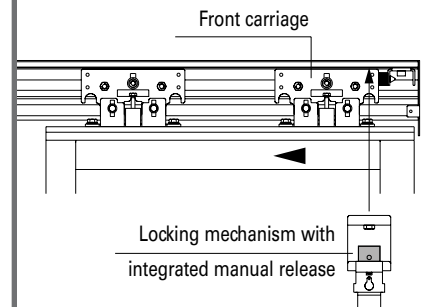

**27**

**NOTE!**

Ensure that when the door is closed and the locking mechanism is on, the door can open manually by at least 2-3 mm. This is necessary to allow the locking mechanism to unhook without hindrance.

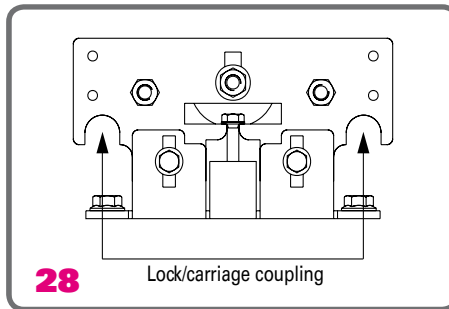

**28**

**CASING ASSEMBLY**

**Assembly**

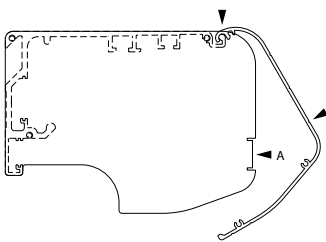

**29**

**Disassembly**

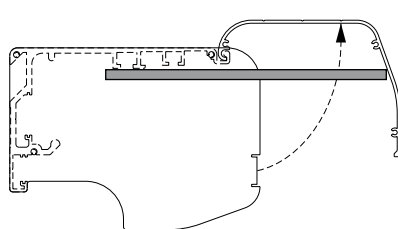

**30**

**ASSEMBLY**

Fasten the side screw caps on the beam if necessary. Insert the upper part of the casing in the appropriate upper position of the beam, keeping it inclined by about 30°. Move the casing to the rebate of the front tabs of the side screw caps. Fix front-wise with the appropriate screws [A].

**DISASSEMBLY**

Remove the front screws [A]. The casing can be removed from the beam by turning it roughly 30°, or alternatively, with a complete 90° turn, can be held open with a special bracket.

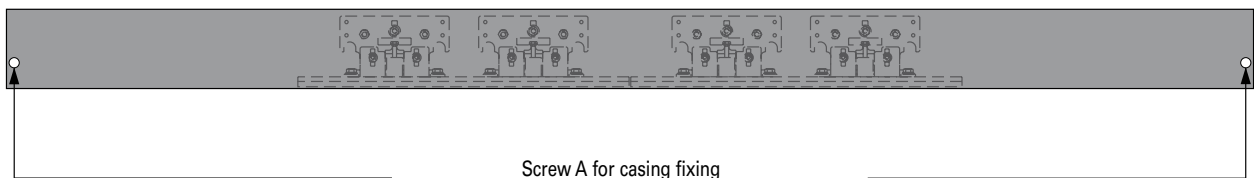

Screw A for casing fixing

# Connections

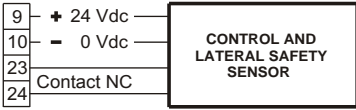

**NOTE ! LATERAL SAFETY**  
If you use the contact 23 e 24  
remove the jumper **J24**

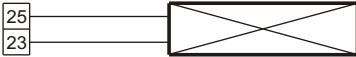

## SAFETY NOTE!

**nc logic** – if the safety contacts are not in use they should be closed with negative 0V dc of terminal 3.

**no logic** – if the safety contacts are not in use they should stay open

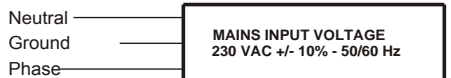
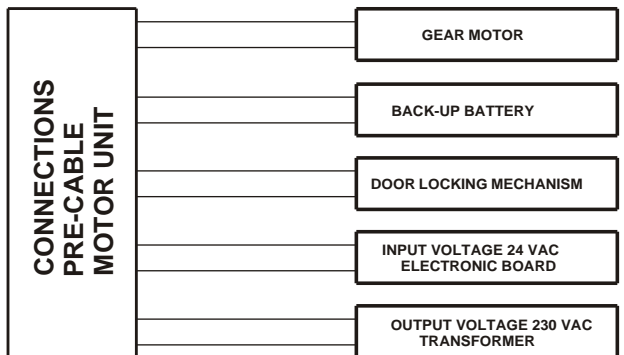
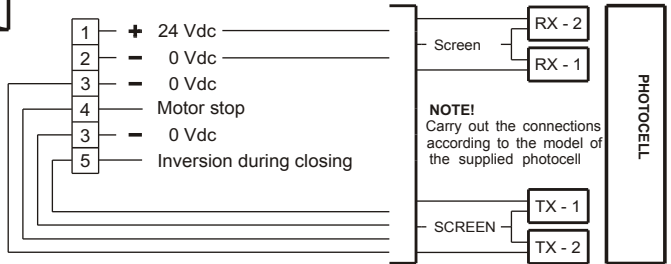
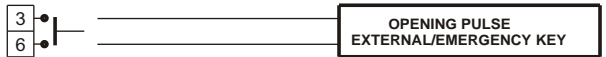
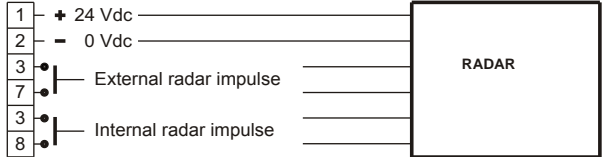
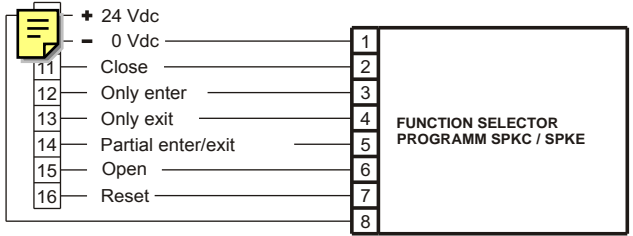

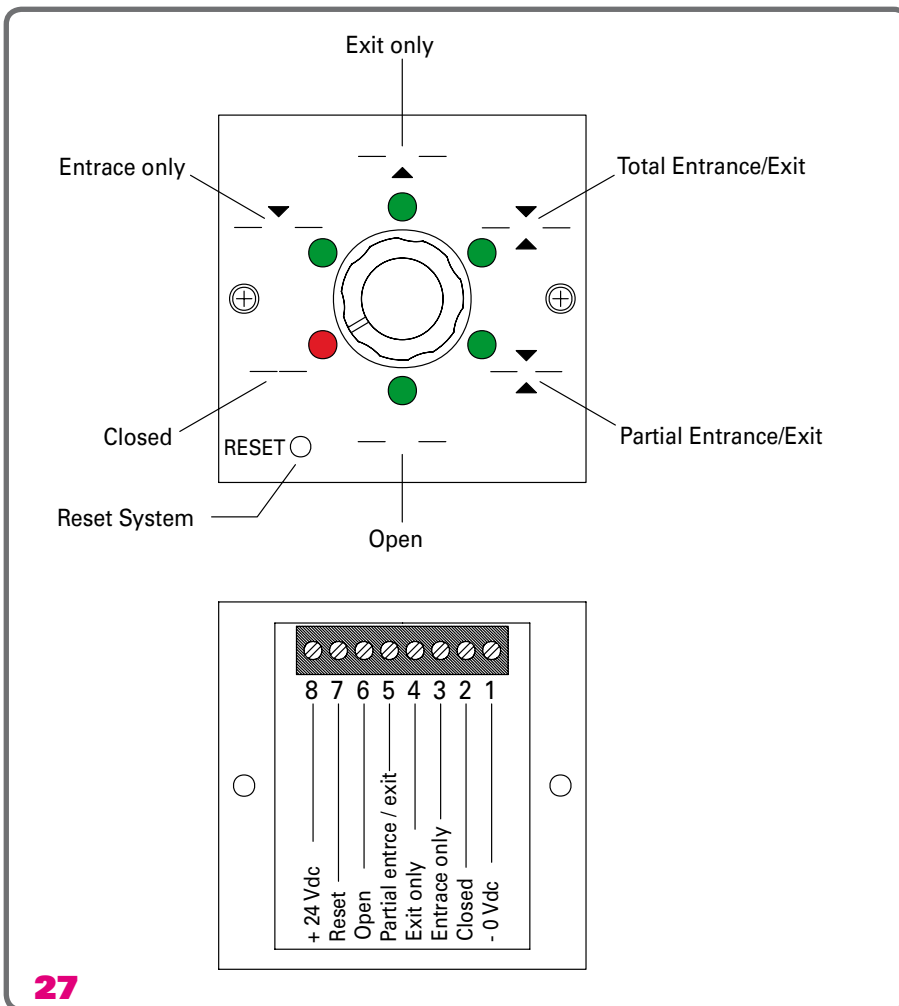

27

## ELECTRICAL CONNECTIONS

The illustration on the left shows a selector type for surface assembly. This device allows the selection of various door operating modes by means of a dial. It is supplied with an LED display which displays the functions selected.

**CLOSED** – Door closes automatically from any position, all sensors are disabled, and the door locking mechanism is activated.

**ENTRY ONLY** – Internal exit sensor is disabled, the external entry sensor is enabled, and the door locking mechanism is activated.

**EXIT ONLY** – External entry sensor is disabled, the internal exit sensor is enabled and the door locking mechanism is activated.

**OPEN** – The door opens automatically from any position, and remains so.

**PARTIAL ENTRY/EXIT** – External/internal sensors are enabled, the door locking mechanism is switched off, and automatic opening of the door is reduced.

**TOTAL ENTRY/EXIT** – External/internal sensors are activated, the door locking mechanism is switched off and automatic opening of the door is total.

**RESET** – Resets the electronic control board and selector.

## BACK-UP BATTERY

### AUTOMATIC EMERGENCY OPENING AND CLOSING

The automation is equipped with a rechargeable back-up battery which, in the event of a mains power failure, will automatically open and close the doors. The doors will remain in the position of the executed action until the mains power is restored. The automation will restart according to the set program when the mains power is restored. Opening and closing is determined by the programming of the electronic board.

### AUTOMATIC SUPERVISION OF THE BACK-UP BATTERY

Function of the back-up battery is constantly controlled by the electronic microprocessor control board. This supervision constantly checks the efficiency of the battery, which in the event of failure locks the door open, signalling the possible breakdown.

### MANUAL EMERGENCY OPENING

When it is necessary that emergency opening does not occur automatically during power failure, it is possible to install a button to manage this function. During power failure, the back-up battery would operate on pressing the button, which should also have a stopping action. To obtain this function, set the [S] parameter to CH and connect the button to contacts 3 and 6 on the electronic board.

### MANUAL EMERGENCY OPENING/CLOSING WITH THE PROGRAM SELECTOR

If necessary, in the event of a power failure, it is possible to open/close the doors using the program selector. By selecting OPEN the door will open and selecting CLOSED the door will close. To obtain this function set the [S] parameter to AP and the [t] parameter to E1.

## DOOR START-UP

Check that mechanical assembly has been carried out correctly. Check that all electrical connections have been carried out correctly. Check that the function selector is not set to CLOSED. Switch on the mains power supply and check that the display of the electronic control board is illuminated. After a few seconds the door will open until it reaches the stopping mechanism, then will close again at low speed (stored manoeuvre of door motion). After having executed this movement the door is ready for operational adjustments (with the standard default parameters set by the manufacturer).

## PROGRAMMING THE OPERATIONAL PARAMETERS

If necessary, depending on the weight and dimensions of the doors, it is possible to change the performance by means of 3 keys on the electronic control board. For parameter changes consult the table 'Programming Parameters'.

# Programming PRESTO PLUS

Programming of the operational parameters of the PRESTO PLUS automation is performed using keys on the electronic control board. Automations are usually supplied with standard parameters, pre-set by the manufacturer, which are suitable for correct operation 90% of the time. Programming must be performed with the doors closed.

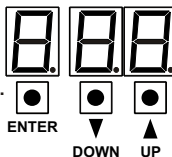

- press the EntEr key until the symbol/letter of the desired parameter is displayed [left display]
- when the parameter value is displayed [centre and right display] press the doWn or uP key
- press the uP key repeatedly, or hold it down, to increase the value
- press the doWn key repeatedly, or hold it down, to decrease the value
- wait about 10 seconds for automatic memory or press the EntEr key again to set another parameter

PROGRAMMABLE PARAMETERS		VALUE	DEFAULT
<b>A</b>	<b>MOTOR THRUST</b>	1-2	[1]
<b>b</b>	<b>OPENING ACCELERATION</b>	1-5	[3]
<b>c</b>	<b>CLOSING ACCELERATION</b>	1-5	[1]
<b>C</b>	<b>OPENING DECELERATIO</b>	1-10	[5]
<b>d</b>	<b>CLOSING DECELERATIO</b>	1-10	[3]
<b>E</b>	<b>OPENING SPEED</b>	15-55 cm/sec	[40]
<b>F</b>	<b>CLOSING SPEED</b>	15-55 cm/sec	[25]
<b>G</b>	<b>SLOWING DOWN OPENING SPEED</b>	1-10 cm/sec	[3]
<b>h</b>	<b>SLOWING DOWN CLOSING SPEED</b>	1-10 cm/sec	[2]
<b>H</b>	<b>SLOWING DOWN OPENING SPACE</b>	1-50 cm	[20]
<b>i</b>	<b>SLOWING DOWN CLOSING SPACE</b>	1-50 cm	[12]
<b>L</b>	<b>PARTIAL OPENING SP</b>	5-95 %	[60]
<b>M</b>	<b>TOTAL AUTOMATIC RE-CLOSING TIME</b>	0-60 sec	[0]
<b>n</b>	<b>PARTIAL AUTOMATIC RE-CLOSING TIME</b>	0-60 sec	[0]
<b>o</b>	<b>AUTOMATIC KEY PULSE RE-CLOSING TIME</b>	0-60 sec	[0]
<b>O</b>	<b>MANUAL AUTOMATIC OPENING</b> WITH VALUE 0 = CLOSED SEAL FORCE	0-10 cm	[2]
<b>P</b>	<b>SAFETY INPUTS</b> [NO = CONTACTS OPEN] - [NC = CONTACTS CLOSED]	NO-NC	[NC]
<b>q</b>	<b>DOOR LOCK LOGIC</b> [OF = NOT ACTIVE] - [CT = CLOSE WITH TENSION] - [ST = CLOSE WITHOUT TENSION]	OF-CT-ST	[ST]
<b>r</b>	<b>DOOR LOCK OPERATION MODE</b> [B0 = ACTS WITH SELECTOR AT CLOSED] [B1 = ACTS WITH SELECTOR AT CLOSED/ENTRY ONLY/EXIT ONLY] [B2 = ACTS WITH SELECTOR AT CLOSED/ENTRY ONLY/EXIT ONLY/ENTER-EXIT]	B0-B1-B2	[B1]
<b>S</b>	<b>OPERATION WITH BATTERY</b> [SC = CONTINUOUS SERVICE] - [AP = EMERGENCY OPENING] - [CH = EMERGENCY CLOSING]	SC-AP-CH	[AP]
<b>t</b>	<b>EMERGENCY OPENING MODE WITH BATTERY</b> [E0 = OPENS WITH SELECTOR AT NEUTRAL] [E1 = DOES NOT OPEN WITH SELECTOR AT CLOSED] [E2 = DOES NOT OPEN WITH SELECTOR AT CLOSED/ENTRY ONLY/EXIT ONLY]	E0-E1-E2	[E1]
<b>u</b>	<b>BATTERY CHECK AND RECHARGE TEST</b> [OF = NOT ACTIVE] - [ON = ACTIVE]	OF-ON	[ON]

**NOTE! When the battery is not installed the [u] parameter should be set at of**

**NOTE! When the door locking mechanism is not installed the [q] parameter should be set at of**

## LIST OF MESSAGES & WARNINGS

### MESSAGE

CH	CLOSING OPERATION SELECTION
SE	ENTRY ONLY OPERATION SELECTION
SU	EXIT ONLY OPERATION SELECTION
EU	ENTRY/EXIT OPERATION SELECTION
PA	PARTIAL OPENING OPERATION SELECTION
AP	ALWAYS OPEN OPERATION SELECTION
SE	MOTOR STOP SAFETY
FE	PHOTOCELL SAFETY
IE	KEY/EMERGENCY PULSE
FE	EXTERNAL RADAR PULSE
FI	INTERNAL RADAR PULSE
EC	CLOSED SEAL FORCE
EB	BATTERY SUPERVISION/TEST

### WARNING MESSAGES

OA	OBSTRUCTION DURING OPENING OPERATION
OC	OBSTRUCTION DURING CLOSING OPERATION
NL	MAINS POWER SUPPLY INTERRUPTED / NOT PRESENT
BE	BATTERY INTERRUPTED / BROKE DOWN / NOT PRESENT
EE	ENCODER / MOTOR BREAKDOWN / BLOCKED DOOR

## PROBLEMS & SOLUTIONS

### PROBLEM

---

On switching on, the display of the electronic control board isn't illuminated. Check mains power supply, contact positions on the electronic control board, transformer voltage 24 V

---

On switching on, the display is illuminated but the doors don't operate. Check device supply voltage, photocell contacts and safety input logic N.O. - N.C.  
Note! After changing the safety input logic press reset.

---

On switching on, the display is illuminated, the doors operate then stop after a few centimetres of movement Check the possibility of sliding friction, the need to increase motor power, encoder

---

After opening the door stays open. Check the photocell contacts, the radar contacts, possible sliding friction, flat battery.

---

While closing, door continues to re-open in continuation. Check position and sensitivity of the radar, photocell alignment and possible sliding friction.

---

When opening and closing, door bangs the stop mechanism without slodoor down. Check and increase the distance of approach and/or braking, door motion setting, motor and/or encoder breakdowns.

---

When opening and closing, door makes excessive noise. Check there is no dirt in the sliding base, carriage alignment, sliding wheels, floor sliding blocks.

---

Door doesn't open with the function selector settings. Check radar contacts, electromechanical lock, selector contacts.

---

Door continuously opens and closes slowly. Check possible permanent friction of the doors, electronic control board, operating parameters.

---

Door won't operate and the display continues to show symbols, numbers or letters. Check the message using the list of messages and warnings.

---

**Note!**  
Take care when executing operations with the electronic control card. HIGH VOLTAGE! Before performing any maintenance or parts replacement disconnect the mains power supply or battery.

## **ACCESSORIES**

**SAFETY AND DETECTION SENSORS** - microwave or infra-red radar, miniature photocells.

**PROGRAM SELECTOR** – dial/key/button electronics.

**ELECTROMECHANICAL DOOR LOCK** – necessary when the door must be kept closed. Operated with the program selector.

**PUSH BUTTON UNITS** – mushroom head, key, ultraflat angled, radio-controlled, pressure sensitive mats.

**ANTI-PANIC BREAKTHROUGH DEVICE** – allows the sliding doors and the semi-fixed side panels to be opened like normal push doors in the event of an emergency

**GLASS DOOR SYSTEM** - kit with adapter and floor sliding block.

**ACCESS CONTROLS** – intelligent interblock, magnetic card swipe system.

## **ASSISTANCE & MAINTENANCE**

It is advisable to carry out maintenance of the automatic doors, the frequency of which depends on environmental conditions and volume of traffic through the doors.

Remove dust and dirt from the automation. Dirt on the sliding track should be removed with a non-abrasive detergent.

There are no components which require lubrication. The cogged belt should be kept dry and clean. Check belt tension.

3. Check that nuts, bolts and screws are well tightened.

4. If necessary, adjust the radar, alignment and door speed.

## CE DECLARATION OF CONFORMITY TYPE B

EUROPEAN DIRECTIVES CEN - CLC AND NATIONAL STANDARDS UNI - CEI

Electromechanical automation for 1 or 2 doors sliding pedestrian doors model:  
**PRESTO PLUS**

Conforms to the following directives:  
Machinery directive 89/392 CEE and modifications  
DPR 459/96 - 91/368 CEE - 93/44 CEE - 93/68 CEE

Low Voltage Directive 73/23 CEE

Electromagnetic Compatibility Directive 89/336 CEE

Harmonised reference norms:  
EN 50081-1, EN 50082-1, EN 55022  
EN 60204-1, EN 60742, EN 60335-1  
IEC 1000-3-2, IEC 1000-3-3

The automation for sliding pedestrian doors subject to the present declaration cannot be put in function or service in the absence of the CE declaration of conformity type A which must be supplied by the fitter.

Malo 01/03/2007

DASPI Gate Automation S.r.l  
via Copernico 76/78,  
36034 Malo • Vicenza • Italia

Spinella Denis  
*Legale Rappresentante*

DASPI AUTOMAZIONE CANCELLI S.R.L. SI  
RISERVA IL DIRITTO DI APPORTARE TUTTE LE  
MODIFICHE CHE RITERRÀ OPPORTUNO AL FINE  
DI MIGLIORARE I PRODOTTI PRESENTI NEL  
SEGUENTE MANUALE. LE ILLUSTRAZIONI E  
FOTOGRAFIE SONO PURAMENTE INDICATIVE.  
E' VIETATO L'USO E LA RIPRODUZIONE  
ANCHE PARZIALE DEL MATERIALE QUI  
PRESENTATO.  
TUTTI I DIRITTI SONO RISERVATI.

DASPI AUTOMAZIONE CANCELLI S.R.L.  
RESERVES THE RIGHT TO MAKE EVERY  
OPPORTUNE CHANGE IN ORDER TO IMPROVE  
ITS PRODUCTS. APPEARING IN THIS MANUAL.  
THE PICTURES AND PHOTOGRAPHS ARE  
JUST AS AN INDICATION. EVERY USE AND  
REPRODUCTION OF THE HERE MENTIONED  
PRODUCTS, OR OF PART OF THEM, IS  
FORBIDDEN.  
ALL RIGHTS ARE RESERVED.

DASPI AUTOMAZIONE CANCELLI S.R.L. SE  
RÉSERVE LE DROIT D'APPORTER TOUTES LES  
MODIFICATIONS QU'ELLE  
JUGE BONNES POUR AMÉLIORER  
LES PRODUITS PRÉSENTS DANS CE MANUEL.  
LES ILLUSTRATIONS ET LES PHOTOGRAPHIES  
SONT PUREMENT INDICATIVES. IL EST  
INTERDIT L'EMPLOI ET LA REPRODUCTION  
MÊME PARTIELLE DE CES DOCUMENTS SANS  
ACCORD ÉCRIT. TOUTS LES DROITS ÉTANT  
RÉSERVÉS.

DASPI AUTOMAZIONE CANCELLI S.R.L. SE  
RESERVA EL DERECHO DE HACER TODAS  
LAS MODIFICACIONES NECESARIAS PARA  
MEJORAR LOS PRODUCTOS PRESENTADOS  
EN ESTE MANUAL. LAS ILUSTRACIONES  
Y FOTOGRAFÍAS SON INDICATIVAS.  
SE PROHÍBE EL UTILIZO Y LA REPRODUCCIÓN  
DE LOS MATERIALES PRESENTADOS,  
O DE UNA PARTE DE ÉSTE.  
TODOS LOS DERECHOS ESTÁN RESERVADOS.

1°

2007

 **DASPI**®

**DASPI AUTOMAZIONE CANCELLI S.R.L.**  
via Copernico 76/78  
36034 Malo • (VI) • Italy  
tel. +39 0445 602261  
fax +39 0445 585035  
www.daspi.it • info@daspi.it